

DRILL POSITION DURING TRANSPORTATION

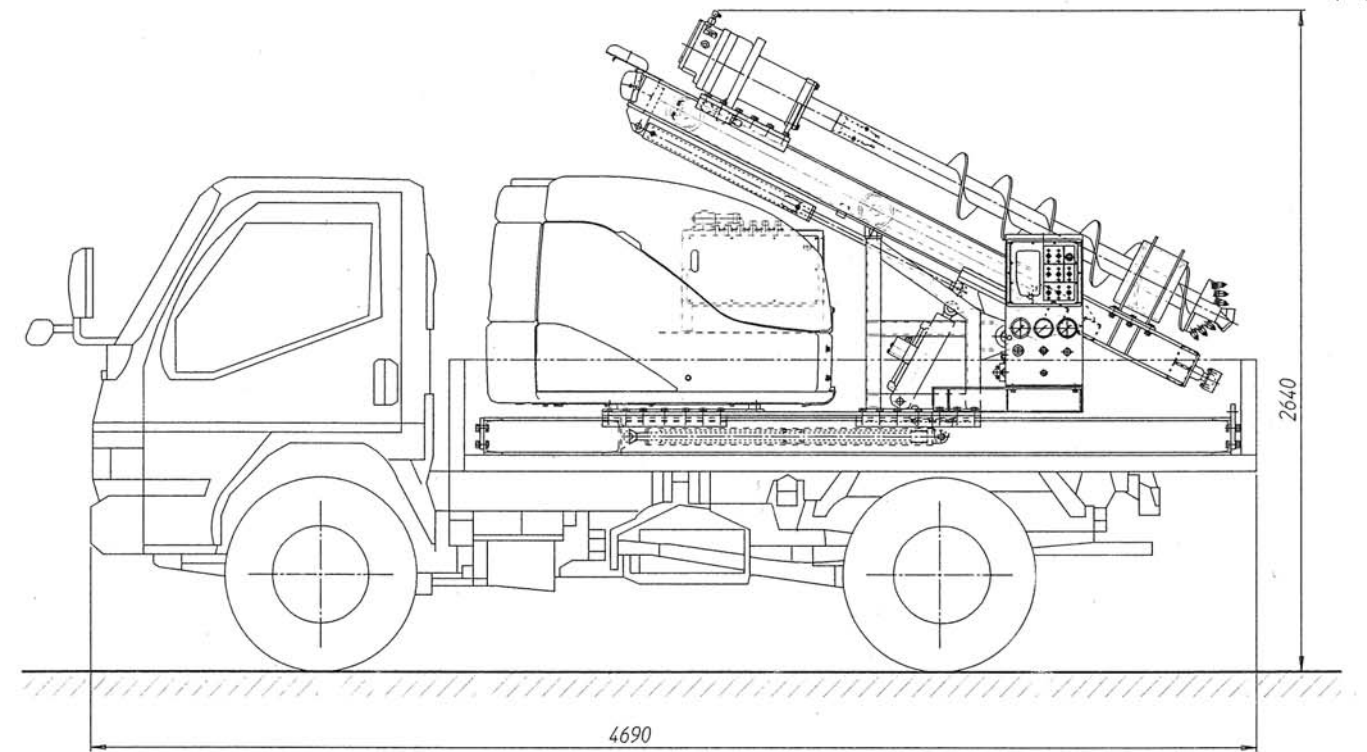

DRILL POSITION DURING OPERATION

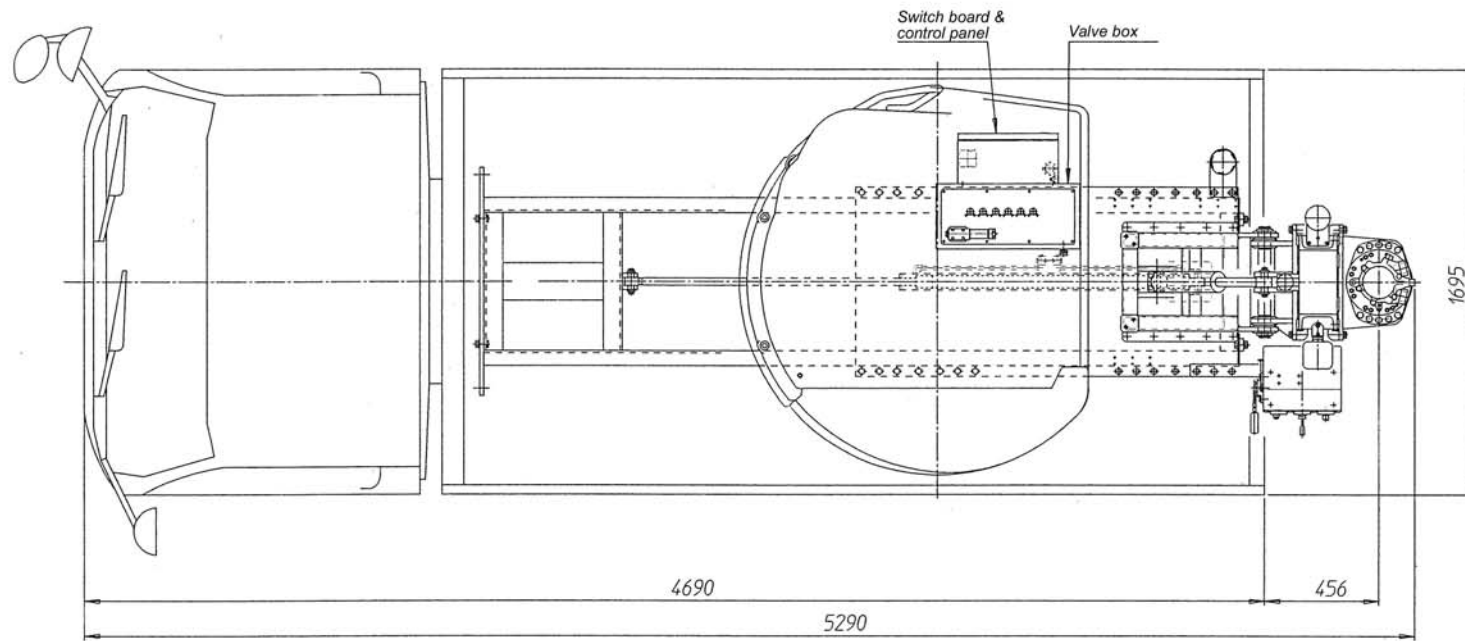
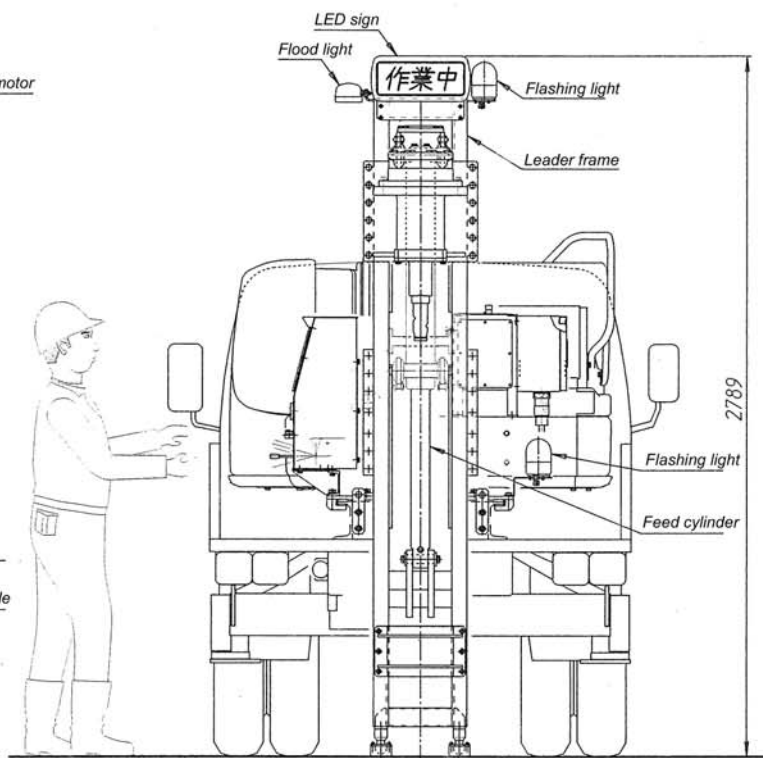
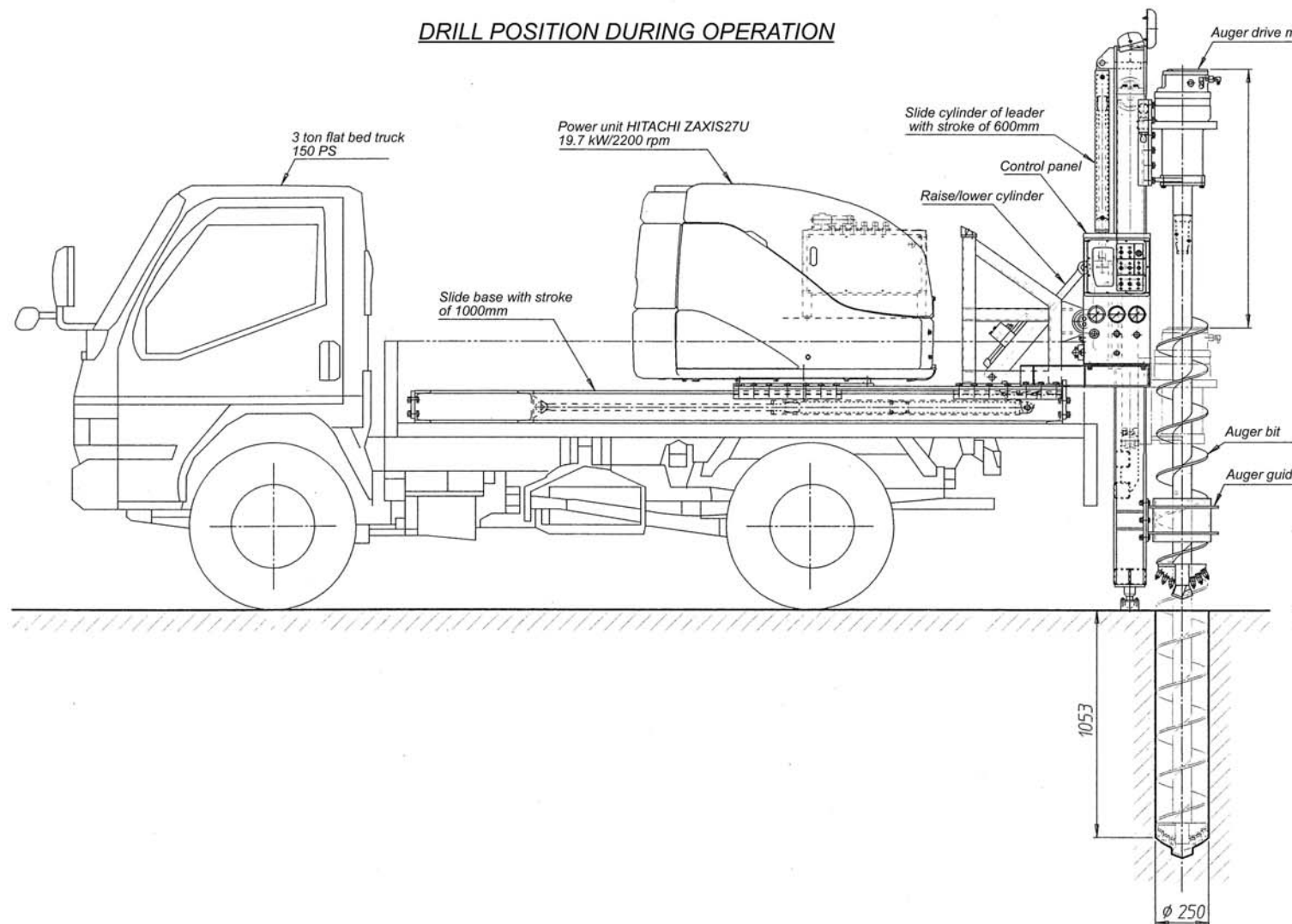

Technical Specifications

Drill Head:

- 1) Type Hydraulic motor driven
- 2) Rotation Low: 28.2 rpm High: 56.4 rpm
- 3) Max. torque Low: 3.9 kNm High: 1.95 kNm at 20 MPa pressure

Feed System:

- 1) Type Hydraulic cylinder
- 2) Feed force 0 - 35.2 kN
- 3) Feed speed 0 - 10.2 m/min.
- 4) Balance force Max. 78.4 kN
- 5) Balance speed 0 - 4.4 m/min.
- 6) Stroke 1.2 m

Mast Frame:

- 1) Raise/lower cylinder 250 mm stroke
- 2) Leader slide 600 mm stroke
- 3) Slide base 1000 mm stroke

Power Unit:

HITACHI ZAXIS27U/19.7kW/2200 rpm

Mounting Truck: 3 ton flat bed, 150 PS

Total Weight: Approx. 4.6 ton

Truck Mounted Soil Auger Drill			
Model "TTS-1"			
品名	数量	単位	kg
1	1	台	4600
B6102-799			
13-8-5			